

Wireless 2-Way Indoor Sounder



Model: RWS332

EN

Installation and User Guide

Language

Page



3

Introduction

RISCO's new Wireless 2-Way Indoor Sounder combines the most advanced technologies within a contemporary, compact and streamlined design, the ideal choice for homeowners seeking the highest safety standards. The indoor sounder has been designed for use in family homes, apartments or small offices. The indoor sounder is easy to install, and is compatible with all RISCO's wireless systems.

How it works

The principal function of the indoor sounder is to receive local alarms from the system's receiver. The indoor sounder can then alert the occupants of the building about the alarm.

Main Features

- Bi-directional wireless communication
- Simple battery replacement performed by the customer
- 85 dBA piezo sound output with adjustable volume
- Built-in test mode activates self test and alarm-sounding
- Ceiling / wall tamper
- Modern look and feel
- Simple to install with incorporated mounting bracket

Installation and Configuration

The indoor sounder can be assembled on the ceiling or on the wall.

Installing the sounder

1. Select the installation location.
2. Twist and remove the plastic mounting bracket from the sounder (see Figure 1).

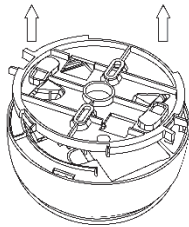

Figure 1

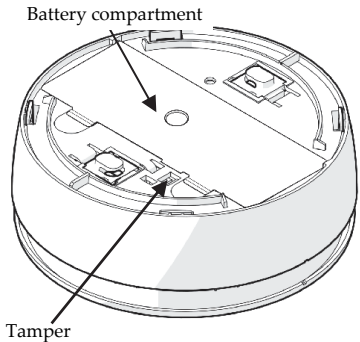

Figure 2

- Using the mounting holes as a template secure the mounting bracket to the mounting surface (see Figure 3).
- Open the battery compartment cover and connect the battery cable to the battery connector (see Figure 4).

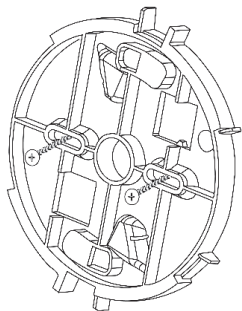

Figure 3

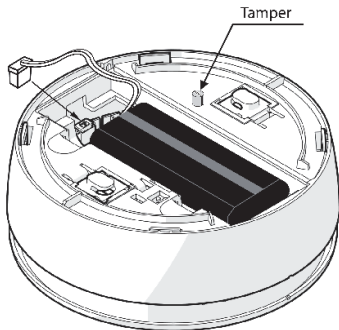

Figure 4

- After a squawk is heard, send an allocation message by pressing the tamper contact for at least 3 seconds (or connect the sounder to the mounting bracket) until the system receiver indicates that it has detected the allocation message. The sounder initiates a second squawk confirming the allocation.

Note: You can also register the sounder by entering the 11-digit serial number.

6. To Install the sounder on the mounting bracket, align the base with the bracket, insert the base hooks fully into the bracket cavities and then turn the detector in the direction of the arrow to secure (see Figure 5).

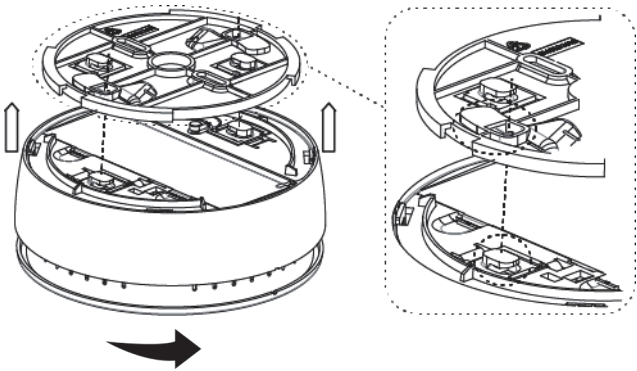

Figure 5

Sounder parameters

The following sounder parameters can be defined from the system receiver:

Parameter	Description
Alarm Volume	Defines the sound produced during an alarm 0-9
Squawk Volume	Defines the sound produced during confirm squawk 0-9
Exit/Entry Volume	Defines the sound produced during exit/entry time 0-9
Supervision Time	Defines the supervision monitoring time 0-255 min.
Pre-alarm	Defines the pre-alarm trigger On/Off

See your system receiver's installation / configuration manual for more information about defining sounder parameters.

Reset button

Pressing the reset button will reset the indoor sounder (*see Figure 6*).

Battery Replacement

To replace the sounder batteries:

Note: To avoid a tamper alarm, enter the system receiver to Service Mode.

1. Remove the sounder from the plastic mounting bracket (*see Figure 1*).
2. Open the battery compartment cover.
3. Remove the battery holder and replace the old batteries with new ones while observing battery polarity (*see Figure 6*).
4. Put back the battery holder.

5. Close the battery compartment cover.

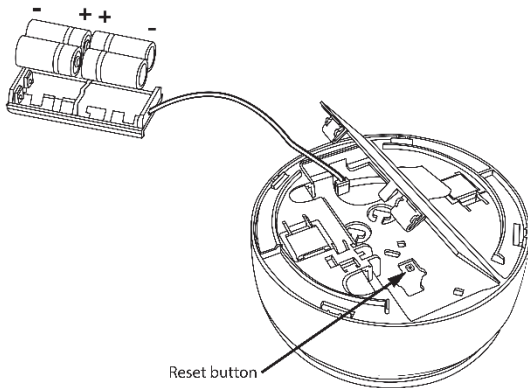

Figure 6

6. Install the sounder on the mounting bracket (see point 6 in *Installing the Sounder*).

CAUTION!

Risk of explosion if battery is replaced by an incorrect type. Dispose of used batteries according to local regulations.

Technical Specification

Parameter	Description
Speaker sound level	85 dB at 1 meter
Indicators	Audible (Piezo)
Average power consumption (alarm sounding)	53mA
Quiescent power consumption (non-alarm sounding)	65 μ A
Battery life	3 years (typical)
Battery type	4 x CR123 3V Lithium battery
Low battery threshold	2.5 V
Siren type	Type W indoor sounder
Maximum sounder duration	Up to 5 min.
Operating temperature	-10 °C to 55 °C (14 °F to 131 °F)
Humidity during operation	10% to 85% RH, no condensation or icing
Color	White
Dimensions (D x H)	130 x 50 mm (5.11 x 1.96')
Weight	295 g (net)
Supervision monitoring	Approx. every 60 min. (adjustable)
Modulation type	ASK
Wireless trans. power	10mW
Wireless range	Up to 150 m (unobstructed)

Standard Compliance	EN50131-1, EN 50131-4 Grade 2 Environmental Class II
---------------------	---------------------------------------------------------

Ordering Information

Model	Description
RWS332	WL Indoor Sounder, 433.92MHz

Standard Limited Product Warranty

RISCO Ltd., its subsidiaries and affiliates (“**Risco**”) guarantee Risco’s hardware products to be free from defects in materials and workmanship when used and stored under normal conditions and in accordance with the instructions for use supplied by Risco, for a period of (i) 24 months from the date of connection to the Risco Cloud (for cloud connected products) or (ii) 24 months from production (for other products which are non-cloud connected), as the case may be (each, the “**Product Warranty Period**” respectively).

Contact with customers only. This Product Warranty is solely for the benefit of the customer who purchased the product directly from Risco, or from any authorized distributor of Risco. Nothing in this Warranty obligates Risco to accept product returns directly from end users that purchased the products for their own use from Risco’s customer or from any installer of Risco, or otherwise provide warranty or other services to any such end user. Risco customer shall handle all interactions with its end users in connection with the Warranty, inter alia regarding the Warranty. Risco’s customer shall make no warranties, representations, guarantees or statements to its customers or other third parties that suggest that Risco has any warranty or service obligation to, or any contractual privity with, any recipient of a product.

Return Material Authorization. In the event that a material defect in a product shall be discovered and reported during the Product Warranty Period, Risco shall, at its option, and at customer’s expense, either: (i) accept return of the defective Product and repair or have repaired the defective Product, or (ii) accept return of the defective Product and provide a replacement product to the customer. The customer must obtain a Return Material Authorization (“**RMA**”) number from Risco prior to returning any Product to Risco. The returned product must be accompanied with a detailed description of the defect discovered (“**Defect Description**”) and must otherwise follow Risco’s then-current RMA procedure in connection with any such return. If Risco determines in its reasonable discretion that any Product returned by customer conforms to the applicable warranty (“**Non-Defective Products**”), Risco will notify the customer of such determination and will return the applicable Product to customer at customer’s expense. In addition, Risco may propose and assess customer a charge for testing and examination of Non-Defective Products.

Entire Liability. The repair or replacement of products in accordance with this warranty shall be Risco’s entire liability and customer’s sole and exclusive

remedy in case a material defect in a product shall be discovered and reported as required herein. Risco's obligation and the Warranty are contingent upon the full payment by customer for such Product and upon a proven weekly testing and examination of the product functionality.

Limitations. The Product Warranty is the only warranty made by Risco with respect to the Products. The warranty is not transferable to any third party. To the maximum extent permitted by applicable law, the Product Warranty does not apply and will be void if: (i) the conditions set forth above are not met (including, but not limited to, full payment by customer for the product and a proven weekly testing and examination of the product functionality); (ii) if the Products or any part or component thereof: (a) have been subjected to improper operation or installation; (b) have been subject to neglect, abuse, willful damage, abnormal working conditions, failure to follow Risco's instructions (whether oral or in writing); (c) have been misused, altered, modified or repaired without Risco's written approval or combined with, or installed on products, or equipment of the customer or of any third party; (d) have been damaged by any factor beyond Risco's reasonable control such as, but not limited to, power failure, electric power surges, or unsuitable third party components and the interaction of software therewith or (e) any delay or other failure in performance of the product attributable to any means of communications, provided by any third party service provider (including, but not limited to) GSM interruptions, lack of or internet outage and/or telephony failure.

BATTERIES ARE EXPLICITLY EXCLUDED FROM THE WARRANTY AND RISCO SHALL NOT BE HELD RESPONSIBLE OR LIABLE IN RELATION THERETO, AND THE ONLY WARRANTY APPLICABLE THERETO, IF ANY, IS THE BATTERY MANUFACTURER'S WARRANTY.

Risco makes no other warranty, expressed or implied, and makes no warranty of merchantability or of fitness for any particular purpose. For the sake of good order and avoidance of any doubt:

DISCLAIMER. EXCEPT FOR THE WARRANTIES SET FORTH HEREIN, RISCO AND ITS LICENSORS HEREBY DISCLAIM ALL EXPRESS, IMPLIED OR STATUTORY, REPRESENTATIONS, WARRANTIES, GUARANTEES, AND CONDITIONS WITH REGARD TO THE PRODUCTS, INCLUDING BUT NOT LIMITED TO ANY REPRESENTATIONS, WARRANTIES, GUARANTEES, AND CONDITIONS OF MERCHANTABILITY, FITNESS FOR A PARTICULAR PURPOSE, TITLE AND LOSS OF DATA. WITHOUT LIMITING THE GENERALITY OF THE FOREGOING, RISCO AND ITS

LICENSORS DO NOT REPRESENT OR WARRANT THAT: (i) THE OPERATION OR USE OF THE PRODUCT WILL BE TIMELY, SECURE, UNINTERRUPTED OR ERROR-FREE; (ii) THAT ANY FILES, CONTENT OR INFORMATION OF ANY KIND THAT MAY BE ACCESSED THROUGH THE PRODUCT BY CUSTOMER OR END USER SHALL REMAIN SECURED OR NON DAMAGED. CUSTOMER ACKNOWLEDGES THAT NEITHER RISCO NOR ITS LICENSORS CONTROL THE TRANSFER OF DATA OVER COMMUNICATIONS FACILITIES, INCLUDING THE INTERNET, GSM OR OTHER MEANS OF COMMUNICATIONS AND THAT RISCO'S PRODUCTS, MAY BE SUBJECT TO LIMITATIONS, DELAYS, AND OTHER PROBLEMS INHERENT IN THE USE OF SUCH MEANS OF COMMUNICATIONS. RISCO IS NOT RESPONSIBLE FOR ANY DELAYS, DELIVERY FAILURES, OR OTHER DAMAGE RESULTING FROM SUCH PROBLEMS.

RISCO WARRANTS THAT ITS PRODUCTS DO NOT, TO THE BEST OF ITS KNOWLEDGE, INFRINGE UPON ANY PATENT, COPYRIGHT, TRADEMARK, TRADE SECRET OR OTHER INTELLECTUAL PROPERTY RIGHT

IN ANY EVENT RISCO SHALL NOT BE LIABLE FOR ANY AMOUNTS REPRESENTING LOST REVENUES OR PROFITS, PUNITIVE DAMAGES, OR FOR ANY OTHER INDIRECT, SPECIAL, INCIDENTAL, OR CONSEQUENTIAL DAMAGES, EVEN IF THEY WERE FORESEEABLE OR RISCO HAS BEEN INFORMED OF THEIR POTENTIAL.

Risco does not install or integrate the product in the end user security system and is therefore not responsible for and cannot guarantee the performance of the end user security system which uses the product.

Risco does not guarantee that the product will prevent any personal injury or property loss by burglary, robbery, fire or otherwise; or that the product will in all cases provide adequate warning or protection.

Customer understands that a correctly installed and maintained alarm may only reduce the risk of burglary, robbery or fire without warning, but is not an assurance or a guarantee that such an event will not occur or that there will be no personal injury or property loss as a result thereof. Consequently Risco shall have no liability for any personal injury, property damage or loss based on a claim that the product fails to give warning.

No employee or representative of Risco is authorized to change this warranty in any way or grant any other warranty.

RED Compliance Statement

Hereby, RISCO Group declares that this equipment is in compliance with the essential requirements and other relevant provisions of Directive 2014/53/EU. For the CE Declaration of Conformity please refer to our website: **www.riscogroup.com**

Contacting RISCO

RISCO Group is committed to customer service and product support. You can contact us through our website www.riscogroup.com or as follows:

Belgium (Benelux)

Tel: +32-2522-7622

support-be@riscogroup.com

China (Shanghai)

Tel: +86-21-52-39-0066

support-cn@riscogroup.com

France

Tel: +33-164-73-28-50

support-fr@riscogroup.com

Israel

Tel: +972-3-963-7777

support@riscogroup.com

Italy

Tel: +39-02-66590054

support-it@riscogroup.com

Spain

Tel: +34-91-490-2133

support-es@riscogroup.com

United Kingdom

Tel: +44-(0)-161-655-5500

support-uk@riscogroup.com

USA

Tel: +1-631-719-4400

support-usa@riscogroup.com



All rights reserved.

No part of this document may be reproduced in any form without prior written permission from the publisher.

© RISCO Ltd. 11/2018

5IN2543 B